

# Modeling of Material Flow During Upsetting Between Parallel Pressure Plates

**Ernő Halbritter**

Department of Materials and Manufacturing Technology  
Széchenyi István University of Applied Sciences,  
Győr, Hungary  
halbritt@szif.hu

*Submitted to HEJ. Manuscript no.: MET-990617-A*

*This version is for internal use only!*

## Abstract

The upsetting of compact and ring-shaped work pieces is a well-known problem of plastic forming. Depending on the conditions of friction a work piece becomes bilge during upsetting. This paper demonstrates the mathematical modeling of material flow with respect to the coefficient of friction. In the presented solution the grade of bilge depends on a free parameter of the velocity field. The best value of this free parameter can be determined by minimization of the power requirement for the forming. By using the applied method the actual deformation of the work piece can be determined with good accuracy.

Keywords: metal forming, modeling, upsetting.

## 1 Introduction

The profile of the work piece was found to be approximately parabolic both on the basis of experimental results [2, 3, 4, 5] and calculations using finite element method [6]. The case of homogeneous deformations, where the velocity field is such that no bilge occurs, has been theoretically described in [2, 3]. Velocity fields resulting in bilge work piece have also been developed, see e.g. However these papers do not take the friction coefficient into account, and are not suitable for the simulation of material flow as pointed out in [7].

## 2 Determination of the velocity field

The scheme of upsetting between parallel plates is shown in Fig. 1.

The points of the deformity zone can be given in a cylindrical system of coordinates by the points  $(r, z)$ , where  $z \in (0, h)$ ,  $r \in (0, f(z))$  (see Fig. 1.). We denote the velocity

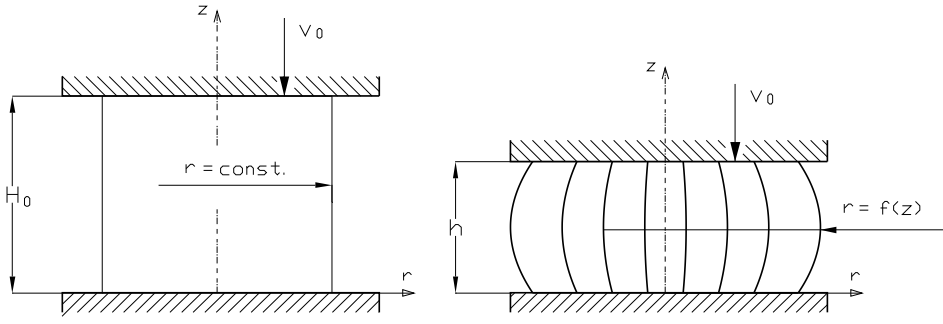

Figure 1: Work piece before and after upsetting

field by  $w(r, z) = [w_r(r, z), w_z(z)]$ . The components of  $w$  can be determined by using the following model assumptions:

1. The material is incompressible.
2. The deformation is axisymmetric, that is

$$w_r(0, z) = 0, \quad \text{for all } z \quad (1)$$

3. The  $z$  component of velocity at the contact of the piece and the plates is as follows:

$$w_z(0) = 0, \quad w_z(h) = -v_0 \quad (2)$$

4. At  $z = h/2$ ,  $w_z$  has a point of inflexion, that is, the deformation velocity  $\dot{\epsilon}$  has an extremum at this point.

5. At  $z = h/2$  the radial velocity component  $w_r$  has a maximum when the work piece has a bilge form.

6. The upset material is homogenous and isotropic.

7. The  $z$ -component of velocity can be written in the form of

$$w_z(z) = a \cdot z^3 + b \cdot z^2 + c \cdot z + d \quad (3)$$

because this function is the simplest asymmetric one to describe the velocity field of the deformation of the work piece. Here  $a$ ,  $b$ ,  $c$  and  $d$  are provisionally unknowns to be determined.

From Assumption 3. we get that

$$d = 0 \quad (4)$$

$$a \cdot h^3 + b \cdot h^2 + c \cdot h = -v_0 \quad (5)$$

From Assumption 4.:

$$\frac{\partial^2 w_z}{\partial z^2} = 3ah + 2b = 0 \quad (6)$$

From equations (4, 5, 6), the values of  $a$  and  $b$  can be determined, whence:

$$w_z(z) = 2 \frac{(ch + v_0)z^3}{h^3} - 3 \frac{(ch + v_0)z^2}{h^2} + cz \quad (7)$$

Assumption 1. implies that the velocity field is divergence free:

$$\dot{\epsilon}_{ii} = \frac{\partial w_r}{\partial r} + \frac{w_r}{r} + \frac{\partial w_z}{\partial z} = 0 \quad (8)$$

By substituting the expression of  $w_z(z)$  into his equation, for the component of  $w_z(r, z)$  we obtain first-order differential equation, that contains  $z$  as a parameter. Condition 2. can be regarded as an initial condition for this equation. So the problem given by formulas (8) and (1) can be solved uniquely for every  $z$ . It is easy to see that the solution is as follows:

$$w_r(r, z) = -3 \frac{rz^2c}{h^2} - 3 \frac{rz^2v_0}{h^3} + 3 \frac{rzc}{h} + 3 \frac{rzv_0}{h^2} - \frac{1}{2} rc \quad (9)$$

where  $c$  is a provisionally arbitrary constant to be determined.

Introducing the nondimensional parameter  $k$  by

$$k = -c \frac{h}{v_0} \quad (10)$$

Equations (7,9) can be rewritten as:

$$w_z(z) = \frac{z(-2z^2kv_0 + 2z^2v_0 + 3zkv_0h - 3zv_0h - kv_0h^2)}{h^3} \quad (11)$$

$$w_r(z, r) = -\frac{1}{2} \frac{r(-6z^2kv_0 + 6z^2v_0 + 6zkv_0h - 6zv_0h - kv_0h^2)}{h^3} \quad (12)$$

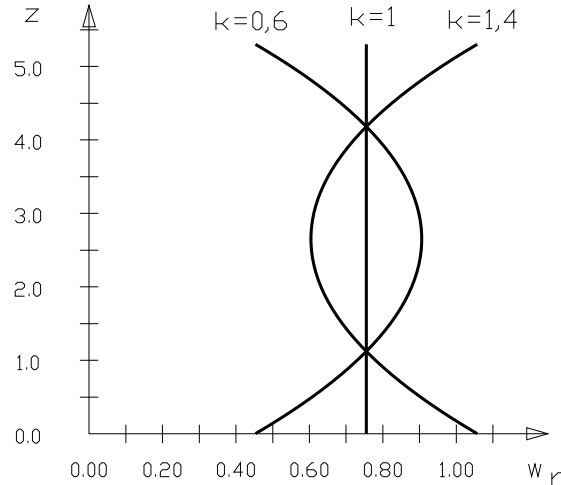

Figure 2: Radial component of the velocity at different values of  $k$  ( $v_0 = 1$ ,  $h = 5.3$ ,  $r = 8$ )

In the above example, at  $k = 1$ , the work piece remains cylindrical, while at  $k = 0.6$  gets bilge and at  $k = 1.4$  the mantle surface of the piece becomes concave. In case of convex shape, at  $z = h/2$ , the deformation velocity  $\dot{\epsilon}_z$  has a maximum, that is,  $w_z(z)$  is steepest in the point of inflexion. (Fig.3).

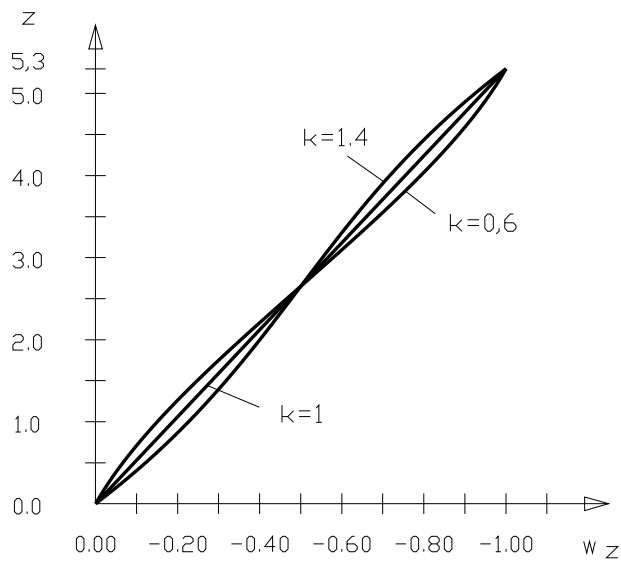

Figure 3: Axial component of velocity at different values of  $k$  ( $v_0 = 1$ ,  $h = 5.3$ ,  $r = 8$ )

In case  $k = 1$  equations (11 and 12) gives the typical forms of homogenous deformations, which is well-known, see e.g. [2, 3]:

$$w_z(z) = -\frac{zv_0}{h} \quad (13)$$

$$w_r(r) = \frac{1}{2} \frac{rv_0}{h} \quad (14)$$

The exact value of  $k$  can be determined by minimization the power requirement of the forming.

### 3 The necessary power of forming

The power requirement of forming is composed as a sum of two components:

$$P(k) = P_{id}(k) + P_s(k) \quad (15)$$

where  $P_{id}$  is the pure power requirement of forming, while  $P_s$  is the friction power which arises between the contact surfaces of the piece and the pressure plates.

Calculation of components see [3] for details:

- $P_{id}$  is the power of pure deformation:

$$P_{id} = \int_V k_f \dot{\epsilon}_e dV$$

where  $k_f$  is the forming strength of the material and  $\dot{\epsilon}_e$  is the comparative deformation velocity.

- $P_s$  is the friction power:

$$P_s = \int_A \mu k_f |v_{rel}| dA$$

assuming the  $\tau = \mu\sigma_n \approx \mu k_f$  which is the Coulomb friction. The  $|v_{rel}|$  is the relative displacement of the piece and the die at the contacting surfaces.

In details, with considering deformation strength at the mean value:

$$P_{id} = 2\pi \bar{k}_f \int_{z=0}^h \int_{r=0}^{f(z)} \dot{\epsilon}_e r dr dz \quad (16)$$

where  $\dot{\epsilon}_e$  comparative deformation velocity can be computed from deformation velocity components  $\dot{\epsilon}_{ij}$ . In case of axisymmetric piece we get:

$$\dot{\epsilon}_e = \sqrt{\frac{2}{3}(\dot{\epsilon}_{ij}\dot{\epsilon}_{ij})} = \sqrt{\frac{2}{3}(\dot{\epsilon}_r^2 + \dot{\epsilon}_z^2 + \dot{\epsilon}_\Theta^2 + 2\dot{\epsilon}_{rz}^2)} \quad (17)$$

The values of  $\dot{\epsilon}_{ij}$  deformation velocity components are as follows:

$$\dot{\epsilon}_{ij} = \frac{1}{2}(w_{i,j} + w_{j,i}) \quad (18)$$

Taking into account that the piece is in contact with the die in two sides, and,  $|v_{rel}| = w_r(r, h) = w_r(r, 0)$ , the friction power can be expressed as follows:

$$P_s = 2P_{s1} = 4\pi \mu \bar{k}_f \int_0^R r w_r dr \quad (19)$$

For the sake of simplicity we perform the calculations for solid cylindrical pieces at  $k = 1$ . A similar example solution is available in [8].

Equation (18) takes the following simple scalar form:

$$\dot{\epsilon}_z = \frac{\partial w_z}{\partial z} = -\frac{v_0}{h} \quad (20)$$

$$\dot{\epsilon}_r = \frac{\partial w_r}{\partial r} = \frac{1}{2} \frac{v_0}{h} \quad (21)$$

$$\dot{\epsilon}_\Theta = \frac{w_r}{r} = \frac{1}{2} \frac{v_0}{h} \quad (22)$$

$$\dot{\epsilon}_{rz} + \frac{1}{2} \left( \frac{\partial w_r}{\partial z} + \frac{\partial w_z}{\partial r} \right) \quad (23)$$

$$\dot{\epsilon}_{r\Theta} = 0, \quad \dot{\epsilon}_{\Theta z} = 0$$

The value of  $\dot{\epsilon}_e$  comparative deformation velocity can be expressed from (20, 21, 22, 23) as:

$$\dot{\epsilon}_e = \sqrt{\frac{2}{3}(\dot{\epsilon}_r^2 + \dot{\epsilon}_z^2 + \dot{\epsilon}_\Theta^2 + 2\dot{\epsilon}_{rz}^2)} = \frac{v_0}{h} \quad (24)$$

From equations (5, 6, 7), we obtain:  $\dot{\epsilon}_z + \dot{\epsilon}_r + \dot{\epsilon}_\Theta = 0$ , so the introduced velocity field satisfies the condition of incompressibility.

The comparative deformation velocity come the components of power, can be expressed in the following form:

$$P_{id} = 2\pi\overline{k_f} \int_{z=0}^h \int_{r=0}^R \frac{v_0}{h} r dr dz = R^2\pi\overline{k_f}v_0 \quad (25)$$

$$P_s = 4\pi\mu\overline{k_f} \int_0^R r \frac{1}{2} \frac{rv_0}{h} dr = \frac{2}{3} \frac{\pi\mu\overline{k_f}R^3v_0}{h} \quad (26)$$

The total power  $P$  can be determined from the velocity  $v_0$  and the mean force  $\overline{F}$ , acting on contact surface.

$$P = \overline{F}v_0 \quad (27)$$

So the power requirement of forming is:

$$\overline{F} = \frac{P_{id} + P_s}{v_0} = \overline{k_f}R^2\pi \left(1 + \frac{2\mu R}{3h}\right) \quad (28)$$

Equation (28) can be derived also by the average stress method, and is known as Siebel-formula (see [2, 3]).

If  $k \neq 1$ , the velocity field changes according to the actual value of  $k$ . Best value of  $k$  bz the upper bound method minimiyes the following function.

$$P(k) = P_{id}(k) + P_s(k) \quad (29)$$

In the case of  $k \neq 1$  the expressions for the power are more complicated, because initial conditions (11, 12) are also more complicated, and

$$\dot{\epsilon}_{rz} = \frac{1}{2} \left( \frac{\partial w_r}{\partial z} + \frac{\partial w_z}{\partial r} \right) \neq 0.$$

Calculations were performed by using mathematical software MapleV (see [9]), see also [1] for a similar industrial applications.

## 4 The character of bilge in the model applied

If  $k \neq 0$ , for calculation of ideal and friction power, bilge character also should be taken into account. For the boundary of integration (relation (16)) and for definition of the radius  $R$  of friction surface (relation (26)), the function  $r = f(z)$ , describing the instantaneous bilge form, is necessary. It makes the exact definition of the function more difficult because that it depends on time also, that is  $r = f(z, t)$ . Considering the displacement of a point of the function under an elementary  $dt$  period, the following equations hold:

$$f(z + w_z(z)dt, t + dt) = f(z, t) + w_r(r = f(z, t), z)dt \quad (30)$$

Expanding the left-hand in terms of Taylr series, we obtain a differential equation which describes the the change of the curve in time:

$$\frac{\partial f(z, t)}{\partial z} \cdot w_z(z) + \frac{\partial f(z, t)}{\partial t} = w_r(r = f(z, t), z) \quad (31)$$

If the curvature of the surface is small enough, the first term of the left-hand side is negligible. Assuming that the initial condition is cylindrical (i.e.  $f(z, t = 0) = \text{constant}$ ), and taking into account that  $w_r$  is a quadratic function of  $z$ , the solution of differential equation (31) is also quadratic in  $z$ . Therefore we approximated the profile curve by a second degree regression curve. Approximation with a second degree curve is quite usual (see e.g. [6]).

Table 1. shows the errors of the approximation relative to the average radius at different values of the coefficient of friction ( $\mu$ ) and the upset height ( $h$ ) see [13]. The initial sizes of the work piece are:  $H_0 = 5.3\text{mm}$ ,  $R_0 = 8\text{mm}$ .

The height of the upset work piece $h$	Relative error			
	$\mu = 0.05$	$\mu = 0.1$	$\mu = 0.15$	$\mu = 0.25$
2.5	—	6.70768E-05	1.73792E-04	5.35802E-04
3	1.29048E-05	5.45206E-05	1.24832E-04	3.51149E-04
3.5	1.17484E-05	3.84116E-05	8.03957E-05	2.10181E-04
4	8.11444E-06	2.23918E-05	4.37545E-05	1.07693E-04
4.5	3.80848E-06	9.30945E-06	1.72268E-05	4.03032E-05
5	6.40259E-07	1.43069E-06	2.53462E-06	5.68641E-06

Table 1: Relative error of approximation

Table 1. clearly shows that:

- the relative error increases with the coefficient of friction and with the degree of upsetting;
- for practical purposes, the profile of the work piece can be approximated with a function of second degree with good accuracy.

Knowing the profile, one can determine the current volume of the work piece and the force requirement of the upsetting. The control calculations justified the volume-consistence with the accuracy of 1–2%.

## 5 Modeling of the deformation process

For the sake of simplicity in the modeling of the deformation process we assumed that the coefficient of friction remains constant during the upsetting. Under such a condition the value of  $k$  depends only on the current height of the work piece. If the value of  $v_0 dt$  is small enough, the value of  $k$  can be considered to be constant during upsetting.

For investigation of the forming process, before upsetting at the cross section of the piece we adopted a set of points, and, by using relations (11, 12), we determined the new position of the adopted point for displacement  $v_0 dt$ . Then we considered the new geometry, and so the value of  $k$  was determined. The procedure can be repeated while we remain in the validity range of the relation (11, 32). At the calculations the value of  $v_0 dt$  was 0.1mm.

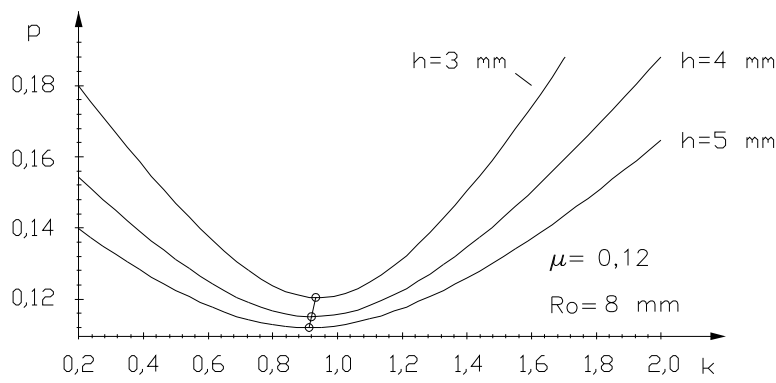

Figure 4: The variation of the specific power requirement of forming depending on the value of  $k$  at different degrees of upsetting. ( $\mu = 0.12$ ,  $H_0 = 5.3\text{mm}$ ,  $R_0 = 8\text{mm}$ )

The way of calculation can be facilitated by expressing the value of  $k$  as a function of the coefficient of friction  $\nu$  and the height  $h$  of the piece to be upset. For a given initial geometry, in a certain range of  $\mu$  friction coefficients and height  $h$ , shown on thw Fig. 6.,  $k$  can be approximated with acceptable accuracy by regression calculation using a function of the type:

$$k = c_1\mu + c_2h + c_3 \quad (32)$$

type of functions.

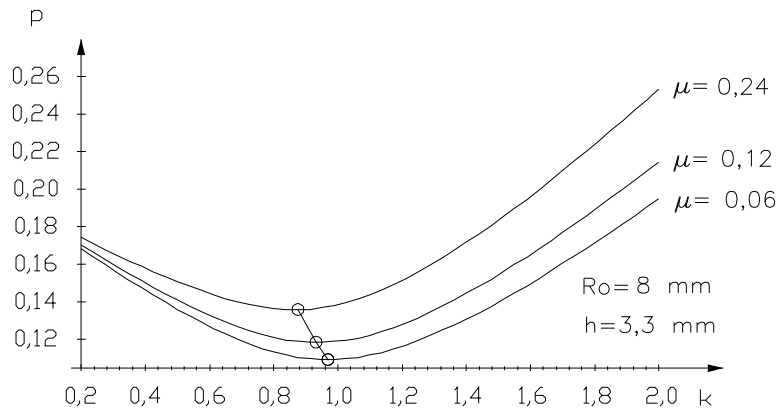

Figure 5: The variation of the specific power requirement of forming depending on the value of  $k$  at different values of friction. The upset height of the work piece is  $h = 3.3\text{mm}$ . ( $H_0 = 5.3\text{mm}$ ,  $R_0 = 8\text{mm}$ )

Applying the above described method we used an AutoLISP program. The program upsets the piece for the desired degree (to  $h$  height) with the given coefficient of friction and in its final stadium draws the picture of the deformed web of dots and the field of velocity (Fig. 7 refers). By means of the deformed set of dots the local deformations can also be studied.



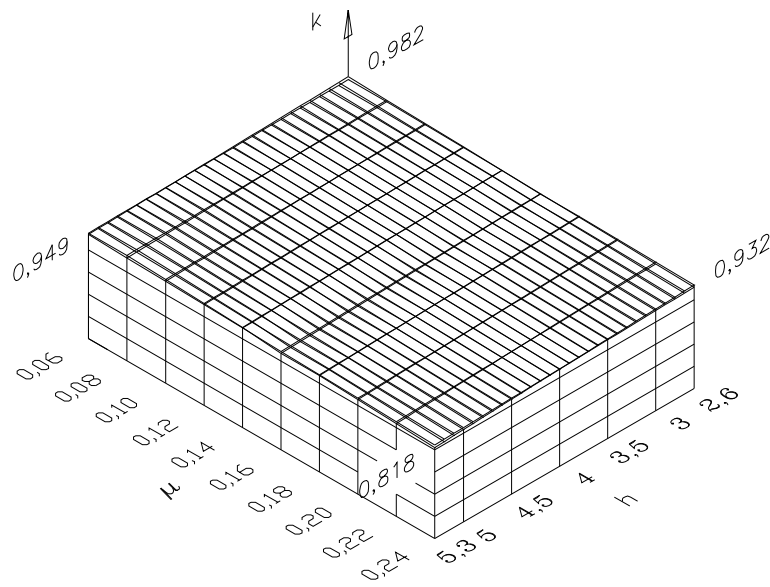

Figure 6: Values of  $k$  as a function of friction coefficient  $\mu$  and the instantaneous  $h$  height of the piece ( $H_0 = 5.3\text{mm}$ ,  $R_0 = 8\text{mm}$ ,  $k = 1.23602 - 0.977926\mu - 0.0865165h$ )

The above modeling makes it possible to investigate the effects of friction coefficient as well.

We present 3 animations of upsetting with  $\eta = 0.06$ ,  $\eta = 0.12$  and  $\eta = 0.24$  as an electronic annex of this paper (see the link).

## 6 The calculation of velocity field for ring shaped pieces

The axial component of velocity described by equation (11) can also be applied to ring shaped pieces. The radial component of velocity we can determine from the following initial condition for the differential equation (8) is

$$w_r(R_s, z) = 0, \text{ for all } z$$

, where  $R_s$  is the radius of the cylindrical surface separating material flowing inwards and outwards [10].

When we already know the actual  $R_s$  value, the displacement of any point of the workpiece can be determined with the help of equation (3). The value of  $R_s$  can be expressed by the friction factor and the actual height of the workpiece (see [11, 12]).

$$R_s = a\mu^b h^c \tag{33}$$

The values  $a$ ,  $b$ ,  $c$  in (33) at certain initial geometry and a friction factor  $\mu$  can be found in the literature (see [12] for details).

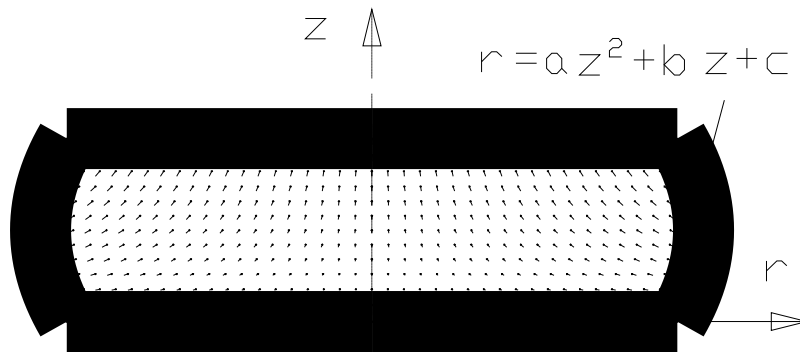

Figure 7: Deformation of the set of points and the instantaneous field of velocity

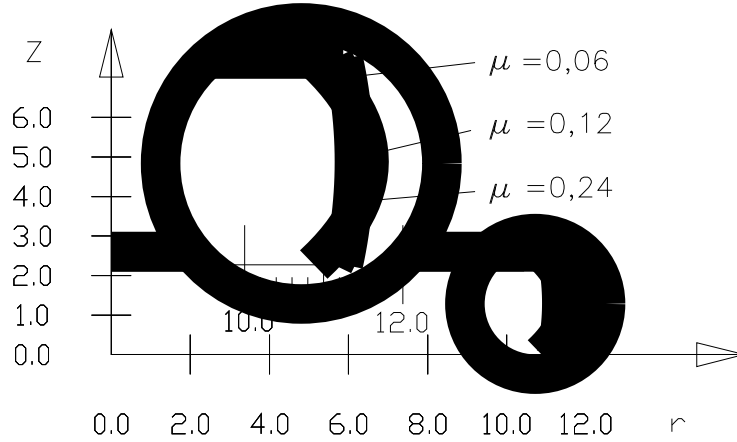

Figure 8: Effects of friction coefficients ( $H_0 = 5.3\text{mm}$ ,  $R_0 = 8\text{mm}$ ,  $h = 2.6\text{mm}$ )

In the case of ring shaped pieces the radial velocity component can be obtained by solving the following differential equation:

$$w_r(r, z) = -\frac{1}{2rh^3}(-6r^2z^2kv_0 + 6r^2z^2v_0 + 6r^2zkv_0h - 6r^2zv_0h - r^2kv_0h^2) \quad (34)$$

$$+ 6R_s^2z^2kv_0 - 6R_s^2z^2v_0 - 6R_s^2zkv_0h + 6R_s^2zv_0h - R_s^2kv_0h^2)$$

Fig. 9 shows some rings with different friction coefficients.

We present 3 animations of ring shape upsetting with  $\eta = 0.06$ ,  $\eta = 0.12$  and  $\eta = 0.20$ .

As far as we know, investigation of deformation during upsetting between parallel pressure plates has not been carried out followed the process by animation.

## References

- [1] Halbritter, E. & Molnárka, Gy.: *Calculation of the Optimal Shape of Nonconical Dies by Minimizing Necessary Forces*, Advances in Engineering Software, 30 (1999)

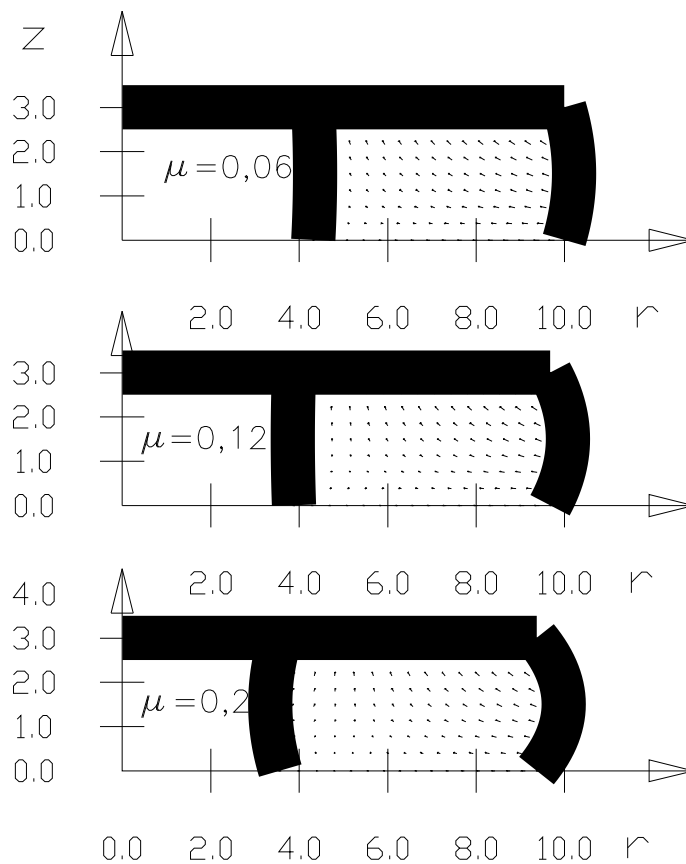

Figure 9: Modeling material flow for ring shape upsetting ( $H_0 = 5.3\text{mm}$ ,  $r_0 = 4\text{mm}$ ,  $R_0 = 8\text{mm}$ ,  $h = 2.5\text{mm}$ )

735-740.

- [2] Lange, K: *Lehrbuch der Umformtechnik, Band1, Band 3*, Springer Verlag 1972., 1974..
- [3] Burgdorf, M.: *Untersuchungen über das Stauchen und Zapfenpressen Berichte aus dem Instiut für Umformtechnik der Universität, Stuttgart*, Nr. 5. 1966.
- [4] Geleji Sándor: *The Theory of Metal Forming, (in Hungarian)*, Akadémiai Kiadó, Budapest, 1967
- [5] Gander, W. & Hrebicek, J.: *Solving Problems in Scientific Computing Using MAPLE and MATLAB*, Springer-Verlag, Berlin, 1995. p. 219–236.
- [6] Roll, K.: *Einsatz numerischer Näherungsverfahren bei der Berechnung von Verfahren der Kaltmassivumformung*, Berichte aus dem Institut für Umformtechnik der Uni., Stuttgart, Nr 66. 1982
- [7] Béda Gyula: *Mechanics IV/2., (in HUngharian)*, Lecture Notes, University of Miskolc TK. Budapest, 1966.

- [8] Dr. Tisza M.: *Technology and Dies of Cold Forming*, Lecture Notes, Univ. of Miskolc, 1982.
- [9] G. Molnárka et al.: *Maple V and its Application, (in Hungarian)*, Springer Hungarica, 1996.
- [10] Burgdorf, M: *Über die Ermittlung des Reibwertes für Verfahren der Massivumformung durch den Ringstauchversuch*, Industrie-Anzeiger, Nr. V 1967.
- [11] Kirchfeld, M. & Halbritter, E.: *Bestimmung des Reibungskoeffizienten mit dem weit-erenwickelten Ringstauchversuch*, 6th DAAAM Symp. 1995. Krakow.
- [12] Kirchfeld, M. & Halbritter, E.: *Modifizierte Auswertung beim Ringstachversuch*, 7th DAAAM Symp. Wien 17–19th October 1996
- [13] Kirchfeld, M. & Halbritter, E.: *Examination of Deformation by Ring Upsetting*, 8th Internationales DAAAM Symposium. Zagreb-Bubrovnik, 23–25th October 1997